

(RESEARCH ARTICLE)



Simulation of obstacle avoidance robots

Mukhtar Ibrahim Bello ¹ and Muhammad Ahmad Baballe ^{2,*}

¹ Department of computer science, School of Technology, Kano state polytechnic, Kano, Nigeria.

² Department of computer engineering technology, School of Technology, Kano state polytechnic, Kano, Nigeria.

Global Journal of Research in Engineering and Technology, 2022, 01(01), 001-012

Publication history: Received on 18 August 2022; revised on 21 September 2022; accepted on 24 September 2022

Article DOI: <https://doi.org/10.58175/gjret.2022.1.1.0011>

Abstract

The first function of the system is to detect the presence of obstacles. When the user activates the system using the power ON/OFF switch, the Arduino microcontroller will read the data. When the ultrasonic sensor detects the presence of an obstacle in the process of moving forward, the robot will move backward. If the robot does not sense any obstacle, that is, if the distance between an obstacle and it is wide, it will then move forward again until it senses an obstacle before it stops. C programming is used for Arduino board applications to develop the program for the whole system's operation. There are three light-emitting diodes; the first one shows the amount of charge in the batteries, while the remaining two show that if the robot is moving forward, one of the two LEDs will be on, and if it is moving backward, one of the LEDs will also be on. There is also a power source unit that is used to charge the batteries used in the system.

Keywords: Simulation; Arduino Uno; Ultrasonic sensor; Robots

1 Introduction

Research on robotic navigation is starting to take off on its own. Experts in robotics began to develop a variety of free routes finding algorithms. Because the robot must be able to be securely controlled from the starting point to the objective (destination), the navigation system is seen to be of utmost importance. The robot must be able to avoid obstacles or, to put it another way, not run into them. This is the first of two aspects that function as a guide. Second, the robot must constantly ensure that it reaches its objective (target). The difficult part is deciding one of the various travel options to choose. In reality, a driver is frequently still plagued by uncertainty when making decisions, like in the example above. If this is implemented in a mobile robot (autonomous robot), it will be quite intriguing. If these issues are applied to autonomous mobile robots with obstacles that the robot must avoid, new issues can be created from simple ones like these. A mobile robot's need to be able to recognize obstacles and decide how to avoid them would lead to complicated issues, not to mention the fact that the main target (goal) can vanish from the camera's field of vision. All of that necessitates an extremely challenging computing procedure. Since the sensor that will be used is a camera sensor, the light intensity is a factor that must also be taken into consideration. The aforementioned elements will make it challenging for the robot to reach its destination. Many studies have been conducted on obstacle avoidance, beginning with the presentation of fuzzy algorithms for reactive navigation for mobile robots in complex situations [1-61]. According to this study, fuzzy logic is fairly effective and responds quickly to challenges. Only static impediments in the robot's workspace are addressed in this study; moving obstacles brought on by moving objects are not taken into account. This study only focused on static obstacles that unexpectedly appeared, but model-based predictive controller (MBPC) using neural networks and ultrasonic sensors is also used to navigate mobile robots around static obstacles that unexpectedly appear in their workspace [62]-[77]. Motion planning and mobile robot pathways using the Dynamic Artificial Neural Network (DANN) method [78] - [80]. A mobile robot can be guided by this research around both static and moving obstacles on a level surface. Generalized Dynamic Fuzzy Neural Networks (GDFNN), a combination of the neural network and fuzzy methods, were used to design real-time control autonomous mobile robots in order to further

* Corresponding author: Muhammad Ahmad Baballe *<https://orcid.org/0000-0001-9441-7023>

improve the robot's ability to overcome obstacle avoidance [81]. The experimental results demonstrate that GDFNN performs better than traditional fuzzy logic control. Additionally, some people use Reinforcement Learning with Neural Networks (RLNN) to solve the obstacle avoidance issue for mobile autonomous robots [82]. The outcomes of the simulation demonstrate that the robot may enhance its capacity for learning and can carry out the tasks set forth in a complicated environment [89–92]. Researchers are beginning to innovate by fusing camera sensors with lasers to detect impediments in real-time. This kind of sensor can accurately identify two- and three-dimensional objects [83]. Stereovision systems were created based on a combination of omnidirectional cameras and perspective cameras, even in more recent research [84]. This method uses a long field of view from a perspective camera and a 360° field of view from an omnidirectional camera to estimate the positions of obstacles in three dimensions. In earlier investigations, a number of vision system implementations based on color sensors [85], camera sensor Pixy 2 CMUcam5 [86], and thermal cameras [87] were examined. The experiments mentioned above produce excellent results, specifically real-time obstacle detection. However, no movable barriers were employed in the earlier studies. The objective of this study is to create a moving obstacle avoidance technique. This project will create an autonomous mobile robot based on previous research that can navigate on its own to avoid moving impediments brought on by environmental changes in the robot's working environment. Two webcams are utilized as stereo vision sensors to identify the environment. Pedestrians are employed as obstacles because their upper bodies can be detected. This object was chosen since the actual environment is where the robot is working. In order to send the robot to the target (destination), the intelligence technique as a control system must be able to deal with the issue of moving impediments in the work area. Neuro-Fuzzy is the control system that is utilized to avoid obstacles. with this investigation, a three-wheeled omnidirectional robot was used with the anticipation that it would be able to navigate obstacles with ease and flexibility. In order for the mobile robot to arrive at a predetermined target (goal), it is necessary to design a robot behavior that has the ability to identify the target object, the ability to detect moving obstacles and make decisions to avoid them flexibly. The robot will use these actions to navigate. The robot is guided from its starting position to its destination using stereo vision and the Neuro-Fuzzy algorithm. Omnidirectional robotics and the Neuro-Fuzzy algorithm are used to help the robot recognize impediments and make decisions that the robot will avoid in order to improve its capacity to deal with changing surroundings. This research focuses on robot navigation systems, which include locating the target (destination), which is considered to always be in the robot's line of sight, identifying obstacles and dodging them, and generating flexible and fluid movements. Pedestrians, who are detected using upper body detection, are the obstacle items used. The robot uses a corridor and an indoor chamber that are each 4 meters long and 4 meters wide as its workspace. Since the robot does not follow a path when walking, this study is not concerned with covering the smallest distance. The goal of this project is to create a stereo vision-based navigation system to assist omnidirectional mobile robots in avoiding obstacles. The suggested approach makes use of the Neuro-Fuzzy algorithm to generate a barrier-free path in real-time and direct the robot's movement so that it is adaptable and fluid. Designing a robot behavior that can recognize the target object, detect moving impediments, and make flexible judgments to avoid them is important in order to direct the mobile robot to reach a predefined location. Examining the robot's navigational behaviors is the aim of this study. As demonstrated, this study increases the state-of-the-art in obstacle avoidance based on the visual sensor for robot navigation systems by using a stereo camera to detect a target and obstacles as input to ANFIS. There are two main parts to the research methodology for this paper. The first stage is to develop a method for controlling the linear and angular velocity of autonomous mobile robots [88].

1.1 How to Create a Robot That Avoids Obstacles Using Ultrasonic Sensors

Before building the robot, it is essential to understand how the ultrasonic sensor works because it will be essential in spotting obstructions. Keeping track of how long it takes to broadcast ultrasonic beams and how long it takes to receive them after they have impacted a surface is the basic principle underlying how an ultrasonic sensor works. The formula is then used to calculate the distance. The trig pin of the HC-SR04 is therefore set high for at least 10 μ s. To transmit a sound beam, eight pulses at a frequency of 40 kHz are used. The signal hits the surface and bounces back, landing on the HC-SR04's receiver echo pin, where it is subsequently picked up. The Echo pin was already very high when the message was sent [94–95].

2 Materials and method

The materials used in this research are shown in Table 1 below

Table 1 Materials used in this research

S/N	Name of components	Number used
1	Arduino Uno	1
2	Ultrasonic sensor	1
3	5-volt DC motor	2
4	LM298N Motor Driver Module	1

2.1 Method

This section of research handles the operation of the whole system. The first function of the system is to detect the presence of obstacles. When the user activates the system using the power ON/OFF switch, the Arduino microcontroller will read the data. When the ultrasonic sensor detects the presence of an obstacle in the process of moving forward, the robot will move backward. If the robot does not sense any obstacle, that is, if the distance between an obstacle and it is wide, it will then move forward again until it senses an obstacle before it stops. C programming is used for Arduino board applications to develop the program for the whole system's operation. There are three light-emitting diodes; the first one shows the amount of charge in the batteries, while the remaining two show that if the robot is moving forward, one of the two LEDs will be on, and if it is moving backward, one of the LEDs will also be on. There is also a power source unit that is used to charge the batteries used in the system.

2.1.1 Arduino Uno with driver motor

This is the pin configuration of how the Arduino Uno is connected with the motor driver, which is used to turn on the motor.

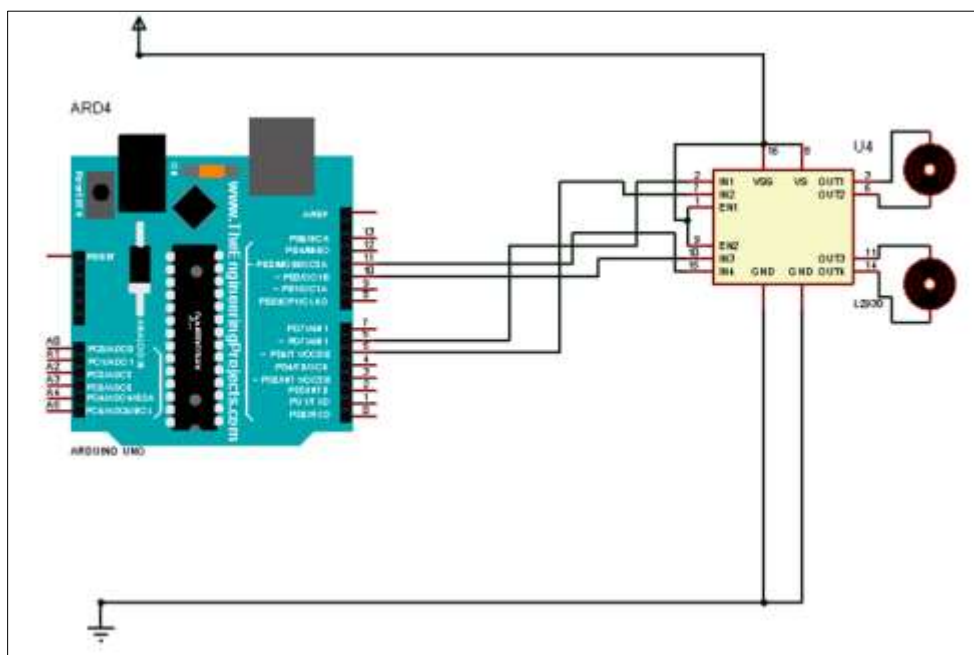

Figure 1 Pin configuration of the Arduino and driver motor

2.1.2 Pin configuration of the Arduino with servo motor

The below diagram shows how the Arduino Uno is connected to the 5-volt servo motor. The ultrasonic sensor is mounted on the servo motor. This motor helps rotate the sensor to detect obstacles.

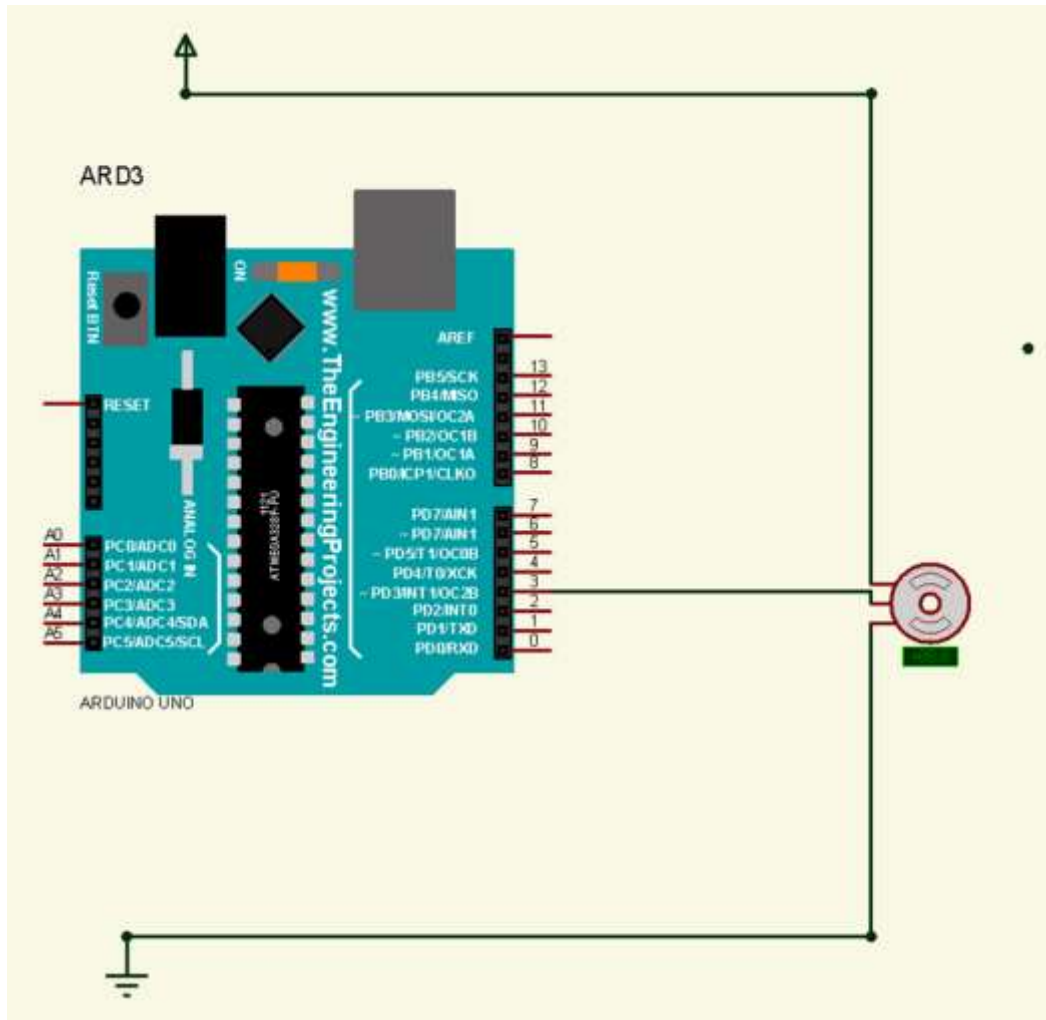

Figure 2 Pin configuration of the Arduino to 5v dc motor

2.1.3 Pin configuration of the Arduino to ultrasonic sensor

The image below shows how the pin of the Arduino Uno is connected to the ultrasonic sensor. This ultrasonic sensor is used to detect an obstacle that is in front of the robot.

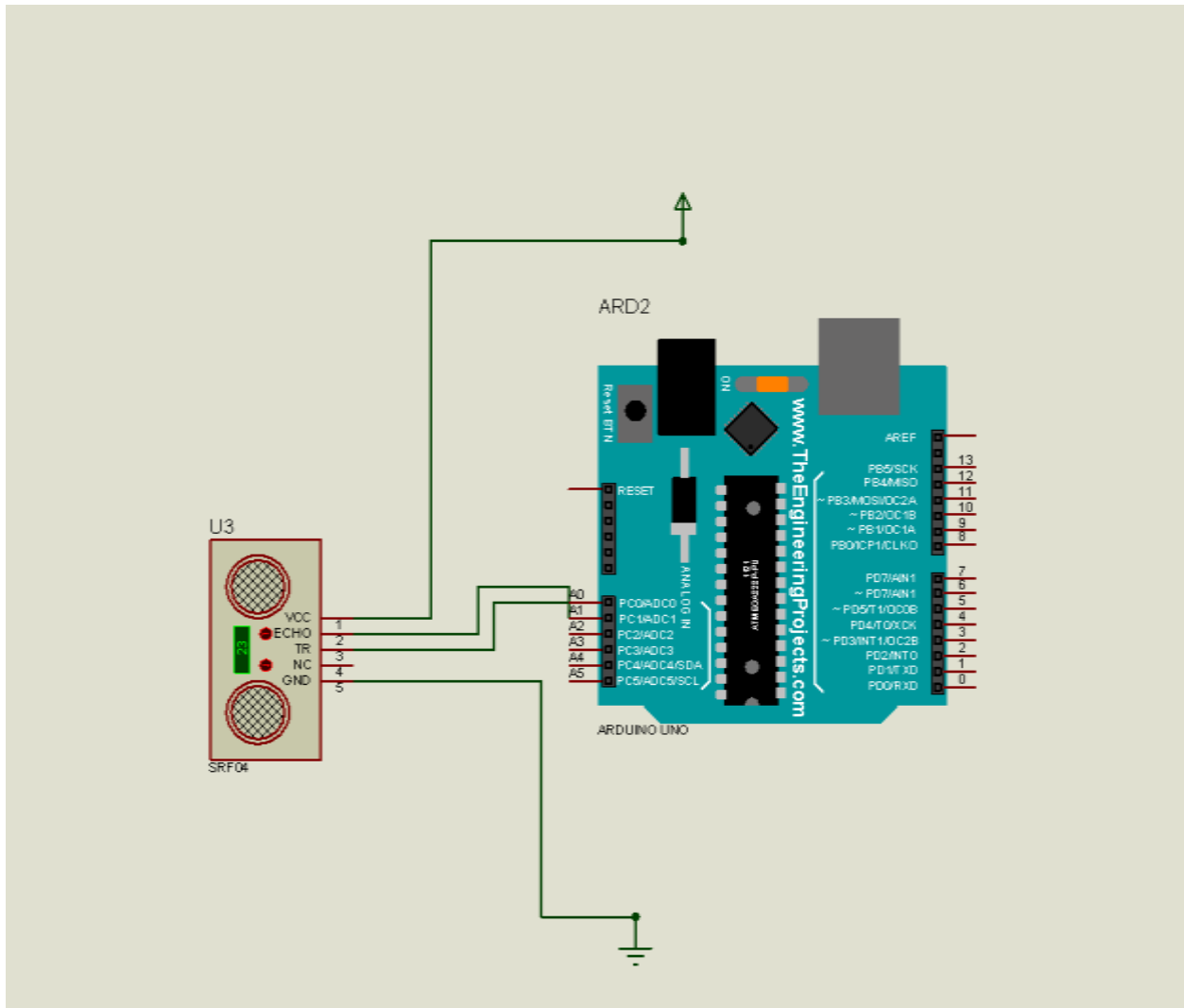

Figure 3 Pin configuration of the Arduino to the ultra-sonic sensor

3 Result

The simulation result is obtained and also shows the whole circuit implementation of the obstacle avoidance robot. The program was written in the Arduino IDE integrated development environment and debugged from the C language into machine code (a hex file). It is then simulated on the PROTEUS ISIS professional and tested. The program was found to be working successfully with some minor errors, which were corrected before the completion of the project. The casing was made using plastic rubber, based on a dimension, and joined using gum rubber.

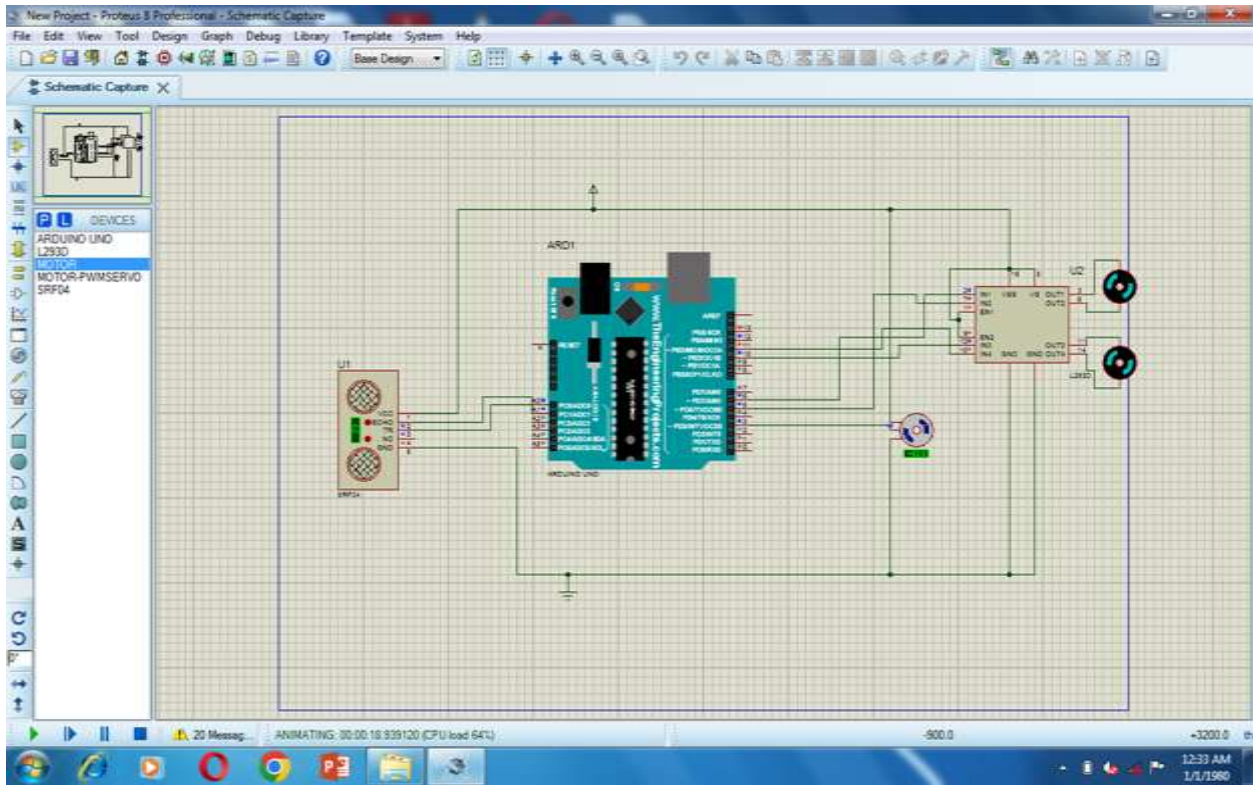

Figure 4 Simulation result of the whole system

4 Conclusion

This research has been successfully completed and tested. The obstacle avoidance robot was tested to sense the presence of an obstacle. Whenever this robot senses the presence of an obstacle, it will move backward until it is far away from the object it senses, then it will move forward again towards this object. This device is useful, and it finds application in diverse areas of life.

Compliance with ethical standards

Disclosure of conflict of interest

No conflict of interest to be disclosed.

References

- [1] T. E. Mora and E. N. Sanchez, Fuzzy logic-based real-time navigation controller for a mobile robot, in Proceedings. 1998 IEEE/RSJ International Conference on Intelligent Robots and Systems. Innovations in Theory, Practice and Applications (Cat. No.98CH36190), vol. 1, pp. 612-617, 1998, doi: 10.1109/IROS.1998.724686.
- [2] L. M. Waghmare, P. Tallapragada, and N. Bidwai, Reactive Navigation of Autonomous Vehicle using Neuro-Fuzzy Controller, in 2006 IEEE International Conference on Industrial Technology, pp. 2681-2685, 2006, doi: 10.1109/ICIT.2006.372675.
- [3] S. Seghour and M. Tadjine, Consensus-based approach and reactive fuzzy navigation for multiple no-holonomic mobile robots, in 2017 6th International Conference on Systems and Control (ICSC), pp. 492- 497, 2017, doi: 10.1109/ICoSC.2017.7958658.
- [4] T. Shen and J. Zhai, Reactive Obstacle Avoidance Strategy Based on Fuzzy Neural Network and Arc Trajectory, in 2019 Chinese Automation Congress (CAC), pp. 4792-4796, 2019, doi: 10.1109/CAC48633.2019.8996374.

- [5] Y. Wang and Y. Yuan, A dynamic reactive power compensation method for high-power and high-voltage electronic motors based on self-adaptive fuzzy PID control, in 2016 IEEE Chinese Guidance, Navigation and Control Conference (CGNCC), pp. 10–15, 2016, doi: 10.1109/CGNCC.2016.7828749.
- [6] E. Ruiz, R. Acuña, P. Véélez, and G. Fernández-López, Hybrid Deliberative Reactive Navigation System for Mobile Robots Using ROS and Fuzzy Logic Control, in 2015 12th Latin American Robotics Symposium and 2015 3rd Brazilian Symposium on Robotics (LARSSBR), pp. 67–72, 2015, doi: 10.1109/LARS-SBR.2015.24.
- [7] P. Chand, Fuzzy reactive control for wheeled mobile robots, in 2015 6th International Conference on Automation, Robotics and Applications (ICARA), pp. 167–172, 2015, doi: 10.1109/ICARA.2015.7081142.
- [8] H. Zerfa and W. Nouibat, Fuzzy reactive navigation for autonomous mobile robot with an offline adaptive neuro fuzzy system, in 3rd International Conference on Systems and Control, pp. 950–955, 2013, doi: 10.1109/ICoSC.2013.6750971.
- [9] A. Melendez and O. Castillo, Optimization of type-2 fuzzy reactive controllers for an autonomous mobile robot, in 2012 Fourth World Congress on Nature and Biologically Inspired Computing (NaBIC), pp. 207–211, 2012, doi: 10.1109/NaBIC.2012.6402263.
- [10] E. Baklouti, M. Jallouli, N. Ben Amor, S. Titi, and A. Nafti, Autonomous mobile robot navigation coupling fuzzy logic and reactive DVZ 3D obstacle avoidance control, in 2015 International Symposium on Innovations in Intelligent Systems and Applications (INISTA), pp. 1–6, 2015, doi: 10.1109/INISTA.2015.7276748.
- [11] Y. Lv and P. Jiang, The Design of Indoor Mobile Robot Navigation System Based on UWB Location, in 2018 Eighth International Conference on Instrumentation & Measurement, Computer, Communication and Control (IMCCC), pp. 334–338, 2018, doi: 10.1109/IMCCC.2018.00077.
- [12] A. Itta, G. Attolico, and A. Distanto, Combining reactive behaviors using a hierarchy of fuzzy controllers, in Ninth IEEE International Conference on Fuzzy Systems. FUZZ- IEEE 2000 (Cat. No.00CH37063), vol. 2, pp. 1041–1044, 2000, doi: 10.1109/FUZZY.2000.839194.
- [13] M. A. O. Mendez and J. A. F. Madrigal, Fuzzy Logic User Adaptive Navigation Control System For Mobile Robots In Unknown Environments, in 2007 IEEE International Symposium on Intelligent Signal Processing, pp. 1–6, 2007, doi: 10.1109/WISP.2007.4447633.
- [14] I. I. Ismail and M. F. Nordin, Reactive navigation of autonomous guided vehicle using fuzzy logic, in Student Conference on Research and Development, pp. 153–156, 2002, doi: 10.1109/SCORED.2002.1033080.
- [15] N. Zhang, D. Beetner, D. C. Wunsch, B. Hemmelman, and A. Hasan, An Embedded Real-Time Neuro-Fuzzy Controller for Mobile Robot Navigation, in The 14th IEEE International Conference on Fuzzy Systems, 2005. FUZZ 05., pp. 319–324, 2005, doi: 10.1109/FUZZY.2005.1452413.
- [16] G. Castellano, G. Attolico, E. Stella, and A. Distanto, Reactive navigation by fuzzy control, in Proceedings of IEEE 5th International Fuzzy Systems, vol. 3, pp. 2143–2149, 1996, doi: 10.1109/FUZZY.1996.552796.
- [17] W. L. Xu and S. K. Tso, Sensor-based fuzzy reactive navigation of a mobile robot through local target switching, IEEE Transactions on Systems, Man, and Cybernetics, Part C (Applications and Reviews), vol. 29, no. 3, pp. 451–459, 1999, doi: 10.1109/5326.777079.
- [18] M. M. Joshi and M. A. Zaveri, Fuzzy Based Autonomous Robot Navigation System, in 2009 Annual IEEE India Conference, pp. 1–4, 2009, doi: 10.1109/INDCON.2009.5409419.
- [19] M. Alwan, P. Y. K. Cheung, A. Saleh, and N. E. C. Obeid, Combining goal-directed, reactive and reflexive navigation in autonomous mobile robots, in 1996 Australian New Zealand Conference on Intelligent Information Systems. Proceedings. ANZIIS 96, pp. 346–349, 1996, doi: 10.1109/ANZIIS.1996.573982.
- [20] A. A. S. Al-Jumaily and S. H. M. Amin, Fuzzy logic-based behaviors blending for intelligent reactive navigation of walking robot, in ISSPA '99. Proceedings of the Fifth International Symposium on Signal Processing and its Applications (IEEE Cat. No.99EX359), vol. 1, pp. 155–158, 1999, doi: 10.1109/ISSPA.1999.818136.
- [21] M. Skubic, S. Graves, and J. Mollenhauer, Design of a two-level fuzzy controller for a reactive miniature mobile robot, in Third International Conference on Industrial Fuzzy Control and Intelligent Systems, pp. 224–227, 1993, doi: 10.1109/IFIS.1993.324183.
- [22] J. L. Overholt, G. R. Hudas, and K. C. Cheok, A modular neural-fuzzy controller for autonomous reactive navigation, in NAFIPS 2005 - 2005 Annual Meeting of the North American Fuzzy Information Processing Society, pp. 121–126, 2005, doi: 10.1109/NAFIPS.2005.1548519.

- [23] W. Li, Fuzzy logic-based robot navigation in uncertain environments by multisensor integration, in Proceedings of 1994 IEEE International Conference on MFI '94. Multisensor Fusion and Integration for Intelligent Systems, pp. 259-264, 1994, doi: 10.1109/MFI.1994.398444.
- [24] N. Melik and N. Slimane, Autonomous navigation with obstacle avoidance of tricycle mobile robot based on fuzzy controller, in 2015 4th International Conference on Electrical Engineering (ICEE), pp. 1- 4, 2015, doi: 10.1109/INTEE.2015.7416799.
- [25] O. Aycard, F. Charpillet, and J.-P. Haton, A new approach to design fuzzy controllers for mobile robots' navigation, in Proceedings 1997 IEEE International Symposium on Computational Intelligence in Robotics and Automation CIRA'97. „Towards New Computational Principles for Robotics and Automation, “ pp. 68-73, 1997, doi: 10.1109/CIRA.1997.613840.
- [26] B. C. Arrue, F. Cuesta, R. Braunstingl, and A. Ollero, Fuzzy behaviors combination to control a nonholonomic mobile robot using virtual perception memory, in Proceedings of 6th International Fuzzy Systems Conference, vol. 3. pp. 1239-1244, 1997, doi: 10.1109/FUZZY.1997.619465.
- [27] W. Li and X. Feng, Behavior fusion for robot navigation in uncertain environments using fuzzy logic, in Proceedings of IEEE International Conference on Systems, Man and Cybernetics, vol. 2, pp. 1790-1796, 1994, doi: 10.1109/ICSMC.1994.400110.
- [28] A. A. S. Al-Jumaily and S. H. M. Amin, Behaviors blending for intelligent reactive navigation of climbing robot, in 2000 26th Annual Conference of the IEEE Industrial Electronics Society. IECON 2000. 2000 IEEE International Conference on Industrial Electronics, Control and Instrumentation. 21st Century Technologies, vol. 2, pp. 795-799, 2000, doi: 10.1109/IECON.2000.972224.
- [29] X. Yang, M. Moallem, and R. V Patel, A fuzzy logic-based reactive navigation algorithm for mobile robots, in Proceedings of 2005 IEEE Conference on Control Applications, 2005. CCA 2005., pp. 197-202, 2005, doi: 10.1109/CCA.2005.1507124.
- [30] Y. Duan and Xin-Hexu, Fuzzy reinforcement learning and its application in robot navigation, in 2005 International Conference on Machine Learning and Cybernetics, vol. 2, pp. 899-904, 2005, doi: 10.1109/ICMLC.2005.1527071.
- [31] W. L. Xu, S. K. Tso, and Y. H. Fung, Sensor-based reactive navigation of a mobile robot through local target switching, in 1997 8th International Conference on Advanced Robotics. Proceedings. ICAR'97, pp. 361-366, 1997, doi: 10.1109/ICAR.1997.620207.
- [32] A. M. Anvar, Intelligent navigation process for autonomous underwater vehicles (AUVs) using time-based fuzzy temporal reasoning, in 10th International Symposium on Temporal Representation and Reasoning, 2003 and Fourth International Conference on Temporal Logic. Proceedings., pp. 56-61, 2003, doi: 10.1109/TIME.2003.1214880.
- [33] H. Maaref and C. Barret, Fuzzy help in mobile robot navigation, in Proceedings IEEE Conference on Industrial Automation and Control Emerging Technology Applications, pp. 387-390, 1995, doi: 10.1109/IACET.1995.527593.
- [34] C. Barret, M. Benreguieg, and H. Maaref, Fuzzy agents for reactive navigation of a mobile robot, in Proceedings of 1st International Conference on Conventional and Knowledge Based Intelligent Electronic Systems. KES '97, vol. 2, pp. 649-658, 1997, Doi: 10.1109/KES.1997.619449.
- [35] A. A. S. Al-Jumaily, S. H. M. Amin, and M. Khalil, A fuzzy multi-behavior reactive obstacle avoidance navigation for a climbing mobile robot, in Proceedings of IEEE International Conference on Intelligent Engineering Systems, pp. 147-152, 1997, Doi: 10.1109/INES.1997.632408.
- [36] W. Li, A hybrid neuro-fuzzy system for sensor-based robot navigation in unknown environments, in Proceedings of 1995 American Control Conference - ACC'95, vol. 4, pp. 2749-2753, 1995, doi: 10.1109/ACC.1995.532349.
- [37] G. Mester, Obstacle Avoidance of Mobile Robots in Unknown Environments, in 2007 5th International Symposium on Intelligent Systems and Informatics, pp. 123-127, 2007, Doi: 10.1109/SISY.2007.4342637.
- [38] M. Benreguieg, H. Maaref, and C. Barret, Fusion of fuzzy agents for the reactive navigation of a mobile robot, in Proceedings of the 1997 IEEE/RSJ International Conference on Intelligent Robot and Systems. Innovative Robotics for Real-World Applications. IROS '97, vol. 1, pp. 388-394, 1997, doi: 10.1109/IROS.1997.649091.

- [39] M. Dupre and S. X. Yang, Two-Stage Fuzzy Logic-Based Controller for Mobile Robot Navigation, in 2006 International Conference on Mechatronics and Automation, pp. 745–750, 2006, doi: 10.1109/ICMA.2006.257683.
- [40] A. Jayasiri, G. K. I. Mann, and R. G. Gosine, Supervisory control of Fuzzy Discrete Event Systems and its application to mobile robot navigation, in 2009 Canadian Conference on Electrical and Computer Engineering, pp. 1147–1151, 2009, doi: 10.1109/CCECE.2009.5090305.
- [41] D. Shi, M. F. Selekwa, E. G. Collins, and C. A. Moore, Fuzzy behavior navigation for an unmanned helicopter in unknown environments, in 2005 IEEE International Conference on Systems, Man and Cybernetics, vol. 4, pp. 3897–3902, 2005, doi: 10.1109/ICSMC.2005.1571754.
- [42] G. Mondelli, G. Castellano, G. Attolico, E. Stella, and A. Distanto, Self-tuning fuzzy logic controller for reactive navigation, in Proceedings of Conference on Intelligent Vehicles, pp. 87–92, 1996, doi: 10.1109/IVS.1996.566358.
- [43] M. F. Selekwa, D. D. Dunlap, and E. G. Collins, Implementation of Multi-valued Fuzzy Behavior Control for Robot Navigation in Cluttered Environments, in Proceedings of the 2005 IEEE International Conference on Robotics and Automation, pp. 3688–3695, 2005, doi: 10.1109/ROBOT.2005.1570682.
- [44] B. B. K. Reddy, B. Kimiaghali, and A. Homaifar, Reactive real time behavior for mobile robots in unknown environments, in 2004 IEEE International Symposium on Industrial Electronics, vol. 1, pp. 693–697, 2004, doi: 10.1109/ISIE.2004.1571890.
- [45] S. Kundu and D. R. Parhi, Behavior-based navigation of multiple robotic agents using hybrid-fuzzy controller, in 2010 International Conference on Computer and Communication Technology (ICCCCT), pp. 706–711, 2010, doi: 10.1109/ICCCCT.2010.5640437.
- [46] A. Safiotti, Fuzzy logic in autonomous robotics: behavior coordination, in Proceedings of 6th International Fuzzy Systems Conference, vol. 1, pp. 573–578, 1997, doi: 10.1109/FUZZY.1997.616430.
- [47] H. Maaref and C. Barret, Progressive optimization of a fuzzy inference system, in Proceedings Joint 9th IFSA World Congress and 20th NAFIPS International Conference (Cat. No. 01TH8569), vol. 1, pp. 47–52, 2001, doi: 10.1109/NAFIPS.2001.944225.
- [48] J. C. Vega Oliver and P. F. Huamaní Navarrete, Fuzzy control to simulate 4 autonomous navigation behaviors in a differential-drive mobile robot, in 2017 IEEE International Conference on Aerospace and Signals (INCAS), pp. 1–4, 2017, doi: 10.1109/INCAS.2017.8123498.
- [49] J. Yung-Jen Hsu, D.-C. Lo, and S.-C. Hsu, Fuzzy control for behaviorbased mobile robots, in NAFIPS/IFIS/NASA '94. Proceedings of the First International Joint Conference of The North American Fuzzy Information Processing Society Biannual Conference. The Industrial Fuzzy Control and Intelligent, pp. 209–213, 1994, doi: 10.1109/IJCF.1994.375097.
- [50] A. Zhu and S. X. Yang, A goal-oriented fuzzy reactive control for mobile robots with automatic rule optimization, in 2010 IEEE/RSJ International Conference on Intelligent Robots and Systems, pp. 3688–3693, 2010, doi: 10.1109/IROS.2010.5651799.
- [51] A. Zhu and S. X. Yang, A fuzzy logic approach to reactive navigation of behavior-based mobile robots, in IEEE International Conference on Robotics and Automation, 2004. Proceedings. ICRA '04, 2004, vol. 5, pp. 5045–5050, 2004, doi: 10.1109/ROBOT.2004.1302517.
- [52] S. Kundu and D. R. Parhi, Fuzzy based reactive navigational strategy for mobile agent, in 2010 International Conference on Industrial Electronics, Control and Robotics, pp. 12–17, 2010, doi: 10.1109/IECR.2010.5720149.
- [53] S. G. Goodridge and R. C. Luo, Fuzzy behavior fusion for reactive control of an autonomous mobile robot: MARGE, in Proceedings of the 1994 IEEE International Conference on Robotics and Automation, vol. 2, pp. 1622–1627, 1994, doi: 10.1109/ROBOT.1994.351358.
- [54] K. C. Tan, K. K. Tan, T. H. Lee, S. Zhao, and Y. J. Chen, Autonomous robot navigation based on fuzzy sensor fusion and reinforcement learning, in Proceedings of the IEEE International Symposium on Intelligent Control, pp. 182–187, 2002, doi: 10.1109/ISIC.2002.1157759.
- [55] M. A. Sotelo et al., Vehicle fuzzy driving based on DGPS and vision, in Proceedings Joint 9th IFSA World Congress and 20th NAFIPS International Conference (Cat. No. 01TH8569), vol. 3, pp. 1472–1477, 2001, doi: 10.1109/NAFIPS.2001.943766.

- [56] A. Howard, B. Werger, and H. Seraji, Integrating terrain maps into a reactive navigation strategy, in 2003 IEEE International Conference on Robotics and Automation (Cat. No.03CH37422), vol. 2, pp. 2012– 2017, 2003, doi: 10.1109/ROBOT.2003.1241889.
- [57] H. Liu, P. Hu, Y. Luo, and C. Li, A goal-oriented fuzzy reactive control method for mobile robot navigation in unknown environment, in 2009 IEEE International Symposium on Industrial Electronics, pp. 1950–1955, 2009, doi: 10.1109/ISIE.2009.5219773.
- [58] H. A. Hagrass, A hierarchical type-2 fuzzy logic control architecture for autonomous mobile robots, IEEE Transactions on Fuzzy Systems, vol. 12, no. 4, pp. 524–539, 2004, doi: 10.1109/TFUZZ.2004.832538.
- [59] S. Kundu and R. P. Dayal, A fuzzy approach towards behavioral strategy for navigation of mobile agent, in INTERACT-2010, pp. 292– 297, 2010, doi: 10.1109/INTERACT.2010.5706164.
- [60] B.-K. Shim, J.-H. Kim, I.-M. Park, and S.-H. Han, An intelligent control of non-holonomic mobile robot based on fuzzy perception, in ICCAS 2010, pp. 2111–2114, 2010, doi: 10.1109/ICCAS.2010.5670182.
- [61] A. A. S. Al-Jumaily and S. H. M. Amin, Blending multi-behaviors of intelligent reactive navigation for legged walking robot in unstructured environment, in 2000 TENCON Proceedings. Intelligent Systems and Technologies for the New Millennium (Cat. No.00CH37119), vol. 2, pp. 297–302, 2000, doi: 10.1109/TENCON.2000.888751.
- [62] J. G. Ortega and E. F. Camacho, Mobile robot navigation in a partially structured static environment, using neural predictive control, Control Eng Pract, vol. 4, no. 12, pp. 1669–1679, 1996, doi: [https://doi.org/10.1016/S0967-0661\(96\)00184-0](https://doi.org/10.1016/S0967-0661(96)00184-0).
- [63] L. E. Zarate, M. Becker, B. D. M. Garrido, and H. S. C. Rocha, An artificial neural network structure able to obstacle avoidance behavior used in mobile robots, in IEEE 2002 28th Annual Conference of the Industrial Electronics Society. IECON 02, vol. 3, pp. 2457–2461, 2002, doi: 10.1109/IECON.2002.1185358.
- [64] O. Gamal, X. Cai, and H. Roth, Learning from Fuzzy System Demonstration: Autonomous Navigation of Mobile Robot in Static Indoor Environment using Multimodal Deep Learning, in 2020 24th International Conference on System Theory, Control and Computing (ICSTCC), pp. 218–225, 2020, doi: 10.1109/ICSTCC50638.2020.9259786.
- [65] A. S. Lafmejani, S. Berman, and G. Fainekos, NMPC-LBF: Nonlinear MPC with Learned Barrier Function for Decentralized Safe Navigation of Multiple Robots in Unknown Environments, 2022 IEEE/RSJ International Conference on Intelligent Robots and Systems (IROS), pp. 10297-10303, 2022, doi: 10.1109/IROS47612.2022.9981177.
- [66] G. Chen et al., Robot Navigation with Map-Based Deep Reinforcement Learning, 2020 IEEE International Conference on Networking, Sensing and Control (ICNSC), pp. 1-6, 2020, doi: 10.1109/ICNSC48988.2020.9238090.
- [67] Y. Pan and J. Wang, A neurodynamic optimization approach to nonlinear model predictive control, in 2010 IEEE International Conference on Systems, Man and Cybernetics, pp. 1597–1602, 2010, doi: 10.1109/ICSMC.2010.5642367.
- [68] N. Hirose, F. Xia, R. Martín-Martín, A. Sadeghian, and S. Savarese, Deep Visual MPC-Policy Learning for Navigation, IEEE Robot Autom Lett, vol. 4, no. 4, pp. 3184–3191, 2019, doi: 10.1109/LRA.2019.2925731.
- [69] T. Ono and T. Kanamaru, Prediction of pedestrian trajectory based on long short-term memory of data, in 2021 21st International Conference on Control, Automation and Systems (ICCAS), pp. 1676– 1679, 2021, doi: 10.23919/ICCAS52745.2021.9649937.
- [70] T. Kim, H. Lee, S. Hong, and W. Lee, TOAST: Trajectory Optimization and Simultaneous Tracking Using Shared Neural Network Dynamics, IEEE Robot Autom Lett, vol. 7, no. 4, pp. 9747– 9754, 2022, doi: 10.1109/LRA.2022.3184769.
- [71] Y. Guo, R. Jena, D. Hughes, M. Lewis, and K. Sycara, Transfer Learning for Human Navigation and Triage Strategies Prediction in a Simulated Urban Search and Rescue Task, in 2021 30th IEEE International Conference on Robot & Human Interactive Communication (RO-MAN), pp. 784–791, 2021, doi: 10.1109/ROMAN50785.2021.9515526.
- [72] A. Polevoy, C. Knuth, K. M. Popek, and K. D. Katyal, Complex Terrain Navigation via Model Error Prediction, 2022 International Conference on Robotics and Automation (ICRA), pp. 9411-9417, 2022, doi: 10.1109/ICRA46639.2022.9811644.

- [73] S. Lai, M. Lan, and B. M. Chen, Model Predictive Local Motion Planning with Boundary State Constrained Primitives, *IEEE Robot Autom Lett*, vol. 4, no. 4, pp. 3577–3584, 2019, doi: 10.1109/LRA.2019.2928255.
- [74] F. Gauthier-Clerc, A. Hill, J. Laneurit, R. Lenain, and É. Lucet, Online velocity fluctuation of off-road wheeled mobile robots: A reinforcement learning approach, in *2021 IEEE International Conference on Robotics and Automation (ICRA)*, pp. 2421–2427, 2021, doi: 10.1109/ICRA48506.2021.9560816.
- [75] E. P. Ferreira and V. M. Miranda, Development of static neural networks as full predictors or controllers for multiarticulated mobile robots in backward movements - new models and tools, in *2011 9th IEEE International Conference on Control and Automation (ICCA)*, pp. 985–990, 2011, doi: 10.1109/ICCA.2011.6138028.
- [76] N. D. Weerakkodi Mudalige et al., DogTouch: CNN-based Recognition of Surface Textures by Quadruped Robot with High Density Tactile Sensors, in *2022 IEEE 95th Vehicular Technology Conference: (VTC2022-Spring)*, pp. 1–5, 2022, doi: 10.1109/VTC2022-Spring54318.2022.9860815.
- [77] X. Zou, B. Sun, D. Zhao, Z. Zhu, J. Zhao, and Y. He, Multi-Modal Pedestrian Trajectory Prediction for Edge Agents Based on Spatial Temporal Graph, *IEEE Access*, vol. 8, pp. 83321–83332, 2020, doi: 10.1109/ACCESS.2020.2991435.
- [78] I. Engedy and G. Horvath, Artificial neural network based mobile robot navigation, in *2009 IEEE International Symposium on Intelligent Signal Processing*, pp. 241–246, 2009, doi: 10.1109/WISP.2009.5286557.
- [79] M. K. Bugeja, S. G. Fabri, and L. Camilleri, Dual Adaptive Dynamic Control of Mobile Robots Using Neural Networks, *IEEE Transactions on Systems, Man, and Cybernetics, Part B (Cybernetics)*, vol. 39, no. 1, pp. 129–141, 2009, doi: 10.1109/TSMCB.2008.2002851.
- [80] J. Yuan, H. Wang, C. Lin, D. Liu, and D. Yu, A Novel GRU-RNN Network Model for Dynamic Path Planning of Mobile Robot, *IEEE Access*, vol. 7, pp. 15140–15151, 2019, doi: 10.1109/ACCESS.2019.2894626.
- [81] M. J. Er, T. P. Tan, and S. Y. Loh, Control of a mobile robot using generalized dynamic fuzzy neural networks, *Microprocess Microsyst*, vol. 28, no. 9, pp. 491–498, 2004, doi: <https://doi.org/10.1016/j.micpro.2004.04.002>.
- [82] B.-Q. Huang, G.-Y. Cao, and M. Guo, Reinforcement Learning Neural Network to the Problem of Autonomous Mobile Robot Obstacle Avoidance, in *2005 International Conference on Machine Learning and Cybernetics*, pp. 85–89, 2005, doi: 10.1109/ICMLC.2005.1526924.
- [83] S. Soumare, A. Ohya, and S. Yuta, Real-time obstacle avoidance by an autonomous mobile robot using an active vision sensor and a vertically emitted laser slit, In *Intelligent Autonomous Systems*, vol. 7, pp. 301–308, 2002.
- [84] M. Lauer, M. Schönbein, S. Lange, and S. Welker, 3D-objecttracking with a mixed omnidirectional stereo camera system, *Mechatronics*, vol. 21, pp. 390–398, 2011.
- [85] M. Tahmasebi, M. Gohari, and A. Emami, An Autonomous Pesticide Sprayer Robot with a Color-based Vision System, *International Journal of Robotics and Control Systems*, vol. 2, no. 1, pp. 115–123, Feb. 2022, doi: 10.31763/ijrcs.v2i1.480.
- [86] S. D. Perkasa, P. Megantoro, and H. A. Winarno, Implementation of a camera sensor pixy 2 cmucam5 to a two wheeled robot to follow colored object, *Journal of Robotics and Control (JRC)*, vol. 2, no. 6, pp. 496–501, Nov. 2021, doi: 10.18196/jrc.26128.
- [87] M. I. Rusydi et al., Autonomous Movement Control of Coaxial Mobile Robot based on Aspect Ratio of Human Face for Public Relation Activity Using Stereo Thermal Camera, *Journal of Robotics and Control (JRC)*, vol. 3, no. 3, pp. 361–373, May 2022, doi: 10.18196/jrc.v3i3.14750.
- [88] F. Umam, M. Fuad, I. Suwarno, A. Ma'arif, and W. Caesarendra, Obstacle Avoidance Based on Stereo Vision Navigation System for Omni-directional Robot, *Journal of Robotics and Control (JRC) Volume 4, Issue 2, March 2023 ISSN: 2715-5072, DOI: 10.18196/jrc.v4i2.17977*.
- [89] M. A. Baballe, A. I. Adamu, A. S. Bari, A. Ibrahim, Principal Operation of a Line Follower Robot, *Global Journal of Research in Engineering & Computer Sciences ISSN: 2583-2727 (Online) Volume 03| Issue 03 | May-June | 2023 Journal homepage: <https://gjrpublication.com/gjrecs/>*.
- [90] M. Çavaş, and M. B. Ahmad, A REVIEW ON SPIDER ROBOTIC SYSTEM, *International Journal of New Computer Architectures and their Applications (IJNCAA) vol. 9, no. 1 pp. 19-24, The Society of Digital Information and Wireless Communications, 2019*.

- [91] M. B. Ahmad, and A. S. Muhammad, A general review on advancement in the robotic system, Artificial & Computational Intelligence, pp. 1-7, Mar 2020, http://acors.org/ijacoi/VOL1_ISSUE2_04.pdf.
- [92] M. A. Baballe, M. I. Bello, A. Hussaini, U. S. Musa, Pipeline Inspection Robot Monitoring System, Journal of Advancement in Robotics, Volume 9, Issue 2, 2022, DOI (Journal): 10.37591/JoARB.
- [93] M. B. Ahmad et al., The Various Types of sensors used in the Security Alarm system, International Journal of New Computer Architectures and their Applications (IJNCAA) 9(2): 50-59 The Society of Digital Information and Wireless Communications, 2019.
- [94] <https://circuitdigest.com/microcontroller-projects/arduino-obstacle-avoiding-robot>.
- [95] A. I. Adamu, A. S. Bari, A. Ibrahim, and M. A. Baballe, The Several uses for Obstacle-Avoidance Robots, Global Journal of Research in Engineering & Computer Sciences ISSN: 2583-2727 (Online) Volume 03| Issue 03 | May/June | 2023 Journal homepage: <https://gjrpublication.com/gjrecs/>.
- [96] M. A. Baballe et al., A Look at the Different Types of Servo Motors and Their Applications, Global Journal of Research in Engineering & Computer Sciences ISSN: 2583-2727 (Online) Volume 02| Issue 03 | May-June | 2022 Journal homepage: <https://gjrpublication.com/gjrecs/>.
- [97] Abdulkadir S. B, Muhammad A. F, Amina I., Mukhtar I. B, & M. A. Baballe. (2023). Elements needed to implement the Obstacle-Avoidance Robots. Global Journal of Research in Engineering & Computer Sciences, 3(3), 18-27. <https://doi.org/10.5281/zenodo.8051131>.